

LEAK-MASTER® MAPMAX

NEW



Automatic in-line micro-leak detection system for packages based on CO₂. LEAK-MASTER® MAPMAX features non-destructive detection of the smallest leaks without the need of costly helium - directly from the packaging line.

CO₂ is the most important gas in the packaging of food under modified atmospheres. The LEAK-MASTER® MAPMAX uses this CO₂ as trace gas. That way it is possible to test the packages for leaks directly after the packing process.

The LEAK-MASTER® MAPMAX places the packages or complete shipping cases precisely in the test chamber. If the test sample is leaking, the pressure difference will result in a gas flow from the package into the chamber and the CO₂-concentration within the chamber rises. The highly sensitive sensor will notice the changes of the CO₂-concentration and even smallest leaks are easily detected.

After each test cycle (up to 15 cycles per minute) the chamber is ventilated and the test sample is moved on to the following system. If a leak has been detected, several potential free contacts for communication with external systems are available (e.g. alarms and/or pusher).

Benefits

- short response time
- high operating speed (max. 15 cycles/min.)
- for single packages or complete shipping cases
- various chamber sizes
- for flexible and rigid packs
- no calibration required
- easy-to-use intuitive system – no special skills required
- operator friendly - data and process parameter entry by means of integrated PLC with touch screen or via remote personal computer
- convenient data administration and evaluation for customer oriented quality documentation
- remote transmission of results via Ethernet
- easy to clean stainless steel housing

Other models, options and accessories available on request.

Product Information

LEAK DETECTION SYSTEMS

www.wittgas.com

Type	LEAK-MASTER® MAPMAX
Drive Mechanism	2 synchronized belt conveyors
Measuring System	ceramic sensor for CO ₂ (calibration not required)
Measuring range	0 ppm – 5.000 ppm (Resolution: 1 ppm)
Response time	approx. 1 sec.
max. CO ₂ concentration in ambient air	2.500 ppm
Leak testing cycle	max. 15 measures/min. depends on leak size, CO ₂ -percentage in package and size of chamber
Operating vacuum	min. 800 mbar abs., max. 200 mbar abs.
Temperature range	5 – 40 °C (41 – 104 °F)
Humidity of ambient air	max. 90% at 20 °C (68 °F) / max. 50% at 40 °C (104 °F)
Alarms	potential free contact; max. 250 V AC or 24 V DC / 2 A
Communication	- data communication via Ethernet - digital output for take-over cycle - digital output for pusher unit
Compressed air connection pneumatic cylinder inlet for pneumatic valves	1 x 14 mm (1 x 0.5 inch) min. 6 to 10 barg min. 6 to 10 barg
Housing	stainless steel
Weight	approx. 750 kg
Machine dimension (HxWxD)	
machine type 1	1700 x 1820 x 1385 mm (66.9 x 71.6 x 54.5 inch)
machine type 2	1700 x 1750 x 1107 mm (66.9 x 68.9 x 43.6 inch)
Take-over-height (h1)	
machine type 1	820 – 1.000 mm (32.3 – 39.4 inch)
machine type 2	815 – 985 mm (32.1 – 38.8 inch)
Test volume (hxwx d)	
machine type 1.1	approx. 140 x 410 x 650 mm (5.5 x 16.1 x 25.6 inch)
machine type 1.2	approx. 140 x 610 x 650 mm (5.5 x 24 x 25.6 inch)
machine type 2.1	approx. 230 x 330 x 400 mm (9 x 13 x 15.7 inch)
Power consumption	380 – 415 V 3 Ph / N / PE 50 Hz
Optional	discharge unit - pusher for leaky packages mounted on synchronized conveyor belt
Approvals	Company certified according to ISO 9001:2000, ISO 14001 and ISO 22000 CE-marked according to: - EMC 89/336/EWG - Low Voltage Directive 73/23/EWG - Machines Directive 98/37/EG

Technical Data

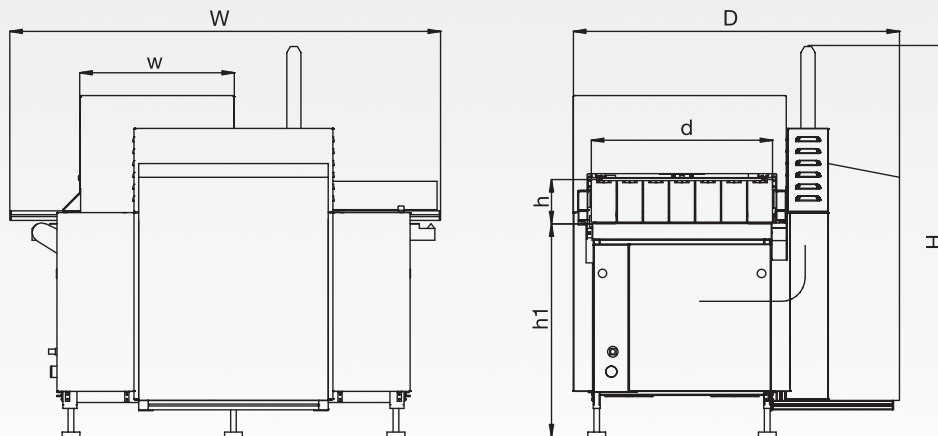

fig. 1.1

K6 subject to change